



1903-1909 EARLY FORD REGISTRY



Member Announcements

December 26, 2015

The George DeAngelis Memorial Research Library is Available On-Line

The first phase of the library addition is now "open for business". Twelve EFR members have already been browsing and downloading material.

More items will be added as time permits and the entry procedure is being refined, but the original plans George made of the Henry Ford 1896 Quadricycle are available right now. We have seen some new members sign-up to our registry to gain access to the plans. Several folks and organizations have made a project of putting the plans in modern computer aided format. More information about this phase will be made at a later date. Our main responsibility is to preserve the original hard copy material and make it available in the future.

Rick Lindner, Secretary-Treasurer, is busy cataloging the material. There are several rolls of 16 mm film in the treasure. After a quick look at the film, Rick forwarded it to **Bruce Balough**, EFR 161, who has the ability to transfer the film record to DVD records. We plan to put the video in the library for all to see and use.



Replica by George DeAngelis

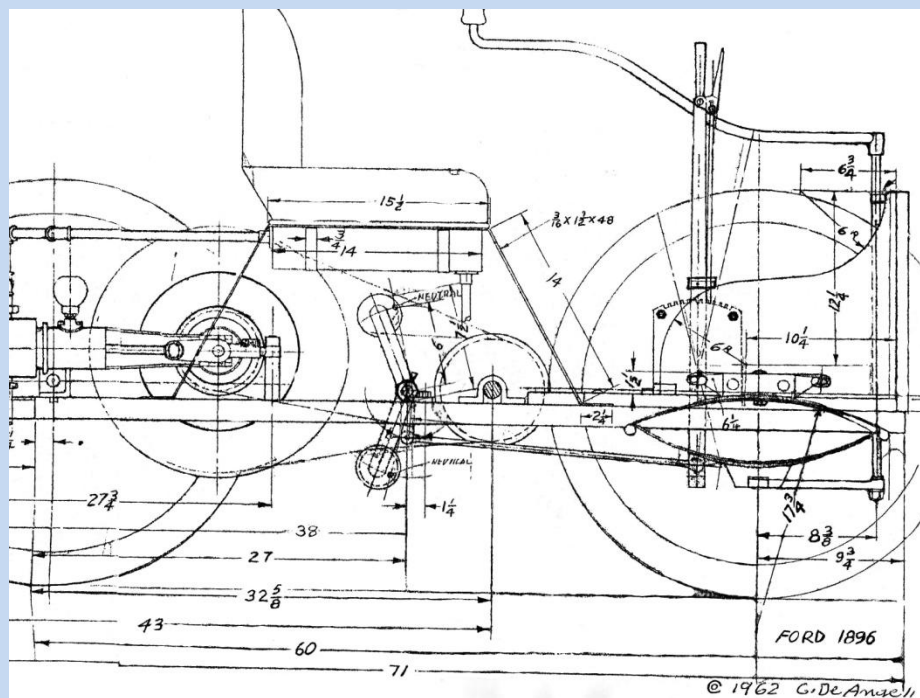

After being copied, some items are being returned to **Patricia DeAngelis**, George's daughter and her mother, **Sidonia (Sid)**, as they requested.

The drawing on the left is typical of the detailed work done by DeAngelis in the early 1960's. He started making measurements and drawings outside the glass case housing Ford's original Quadricycle. After a period of time, the officials at the museum recognized if DeAngelis was going to complete his project, they wanted it to be as accurate as possible.

(continued on page 2)

The George DeAngelis Memorial Research Library is Available On-Line

(continued from page 1)

When you login to see/read/download the material, we are counting the activity so we can analyze how to make the presentation better. You will notice we ask for your email address, this will be replaced with an automatic system using cookies to record that data without making you type in you address. We anticipate this phase to be complete in January.

We ask for your feedback by the users forum, email (dave@efr1.com), and telephone (563.387.3736). Enjoy our fantastic new opportunity.

Dave Dunlavy,
Newsletter Editor and Webmaster

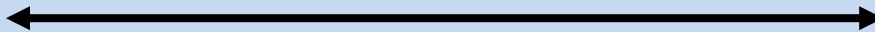

Election Results and 2016 Officers Announcement Coming Soon!

The voting deadline has passed and **Rick Lindner**, Secretary-Treasurer, is tallying the ballots. He informs me the vote was very close. When he confirms the count and informs the candidates, he will let us know the results and we will inform you by *E-mail Update*.

We expect the 2016 Officers to be elected soon also. Stay tuned.

Year-end thoughts

We have been so Blessed this Year with Safety and Peace in most of the USA. The health of the EFR has never been better. New tasks have been started, work accomplished, and some finished. There should be no reason to remind you we are here to have fun preserving the history given us by our forefathers. Already, we are looking forward in 2016, to seeing old friends and making new ones - - all while driving and showing our old Ford cars.

Thank you, Mr. Ford. We owe you a lot.



The picture on the left is not Henry Ford, but our own **Timothy Kelly**, EFR 277, posing with an unidentified potential driver and member. Tim was driving his 1904 Ford Model AC Runabout, when we stopped at the Sportsman's Den in Lake Henry, Minnesota on last year's Paynesville tour.

Happy New Year!

Dave Dunlavy

Newsletter Editor
and Webmaster



2015 Board of Directors

Richard Emery, 2013-2015

Rick Lindner, 2014-2016

Dave Shadduck, 2014-2016

John Grace, 2015-2017

Paul Mikeska, 2013-2015

Jerry VanOoteghem, 2013-2015

Rob Heyen, 2015-2017

Ned Protexter, 2014-2016

Bruce VanSloun 2015-2017



Important Dates to Remember

March 17-18, 2016, *The 26th Annual National Pre-War Swap Meet* at Chickasha, OK. The meet has the largest selection of brass era parts anywhere. It is limited to automobiles, parts, transportation items pre-1945. There is plenty of free parking, and admission is free. Get complete information at website www.pwsm.com or call Mike or Susie Ersland at 405.224.9090.

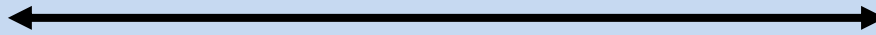

The 1903-1909 Early Ford Registry, Inc. (EFR) is a Chapter of The Model T Ford Club of America (MTFCA) and an Affiliated Register of the Horseless Carriage Club of America (HCCA). You must be a member of the Horseless Carriage Club of America and we encourage membership in the Model T Ford Club of America. We welcome anyone with an interest in Ford automobiles manufactured from 1903 through 1909 (those were generally manufactured in the first manufacturing plant that Ford Motor Company built, the Piquette Plant). You do not need to own a car of this vintage to be a member of the EFR. Annual membership dues: \$15 US to receive Newsletters by email - \$50 US to receive Newsletters by USPO in the USA.

We are a 501(c)3 Non-profit tax-exempt educational corporation. This means you may make tax deductible donations of material and money to us and receive a receipt letter which may be used to itemize your Income Tax. The corporate office is 2895 Bluffton Road, Decorah, Iowa 52101-7802. The web page is www.EarlyFordRegistry.com You may read or download a brochure about our organization here – www.EarlyFordRegistry.com/about1.htm The Webmaster's Email address is Webmaster@EarlyFordRegistry.com.

The 1903-1909 Early Ford Registry, Inc. is not responsible for any incorrect technical information contained herein. The opinions expressed in this newsletter are those of the authors and are not necessarily those of the editor or EFR. Material appearing herein may not be used without the written consent of The 1903-1909 Early Ford Registry, Inc.



Information about The Model T Club of America - *How to Join.*

All persons interested in Early Fords are encouraged to become members of **The Model T Ford Club of America**. Annual dues are \$40.00 for U S members, \$50.00 for Canadian members, and \$56.00 for members in other countries. Membership includes six issues of *Vintage Ford*. You can contact the MTFCA Office by writing: **MTFCA, PO Box 126, Centerville, IN 47330-0126**. Telephone: 765.855.5248. E-mail admin@mtfca.com. Website is www.mtfca.com



Information about the Horseless Carriage Club - *How to Join.*

Any person interested may join the **Horseless Carriage Club**. Annual dues are \$45.00 for US members, \$55.00 for members outside the USA. Membership includes six issues of the *Horseless Carriage Gazette*. You can contact the HCCA Office by writing: **HCCA, 1301 N Manship PL, Meridian ID 83642**. Telephone: 626.287.4222. E-mail office@hcca.org. Website is www.hcca.org